

仕様 SPECIFICATIONS			
引出精度 INDEXING ACCURACY	20 sec/deg	許容慣性質量 ALLOWABLE MASS OF WORK	慣性 250 kg 立昇 125 kg
再現精度 REPEATABILITY	4 sec/deg	許容切削ワーク径 ALLOWABLE WORK DIA.	φ250 mm
テーブル最高回転速度 MAXIMUM ROTATIONAL SPEED	93.3 min ⁻¹ (ワーク 3000 min ⁻¹)	減速比 REDUCTION RATIO	1/90
クランプトルク CLAMPING TORQUE	1000N・m (静圧 0.5MPa)	質量 MASS OF ROTARY TABLE	95 kg
許容最大圧力 MAXIMUM PNEUMATIC PRESS	0.7 MPa	慣性モーメント MOUING INERTIA (GEARED TO MOTOR SHFT)	0.000381 kgm ²

スピンドル穴
SPINDLE THRU-HOLE

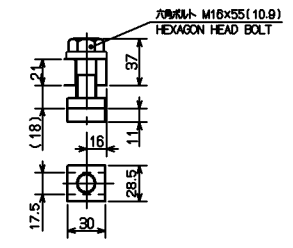

クランプ器具 付属品 4組
CLAMPING PARTS ACCESSORY 4 PAIR

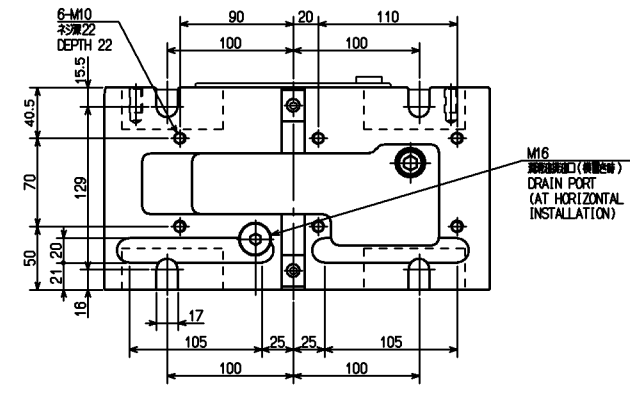
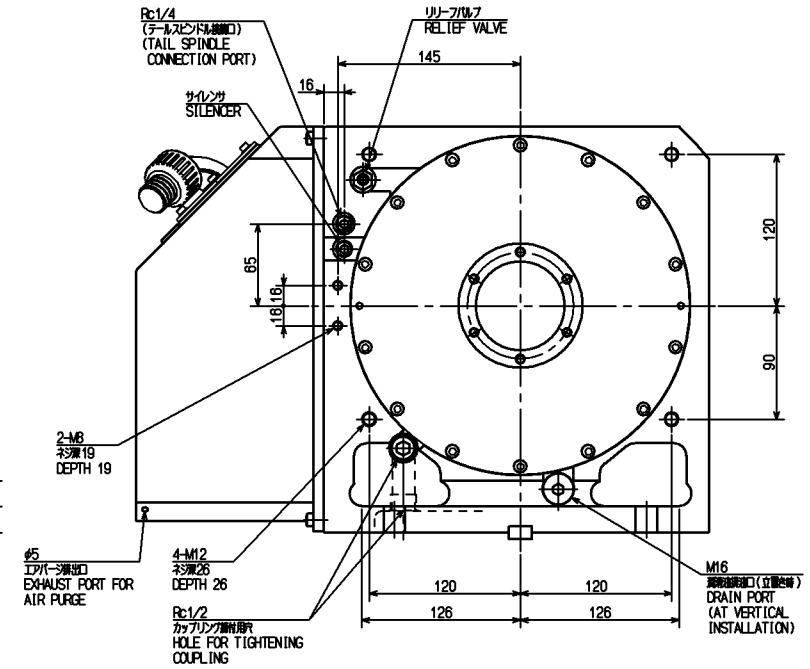
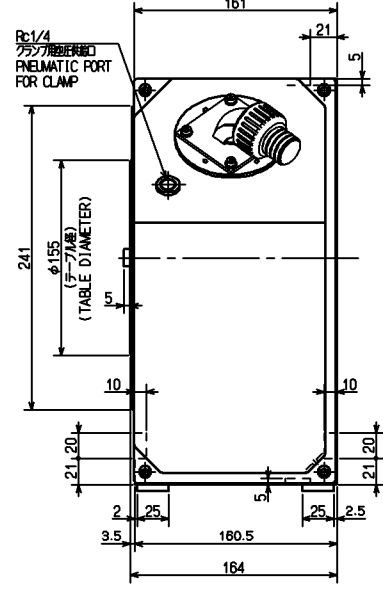
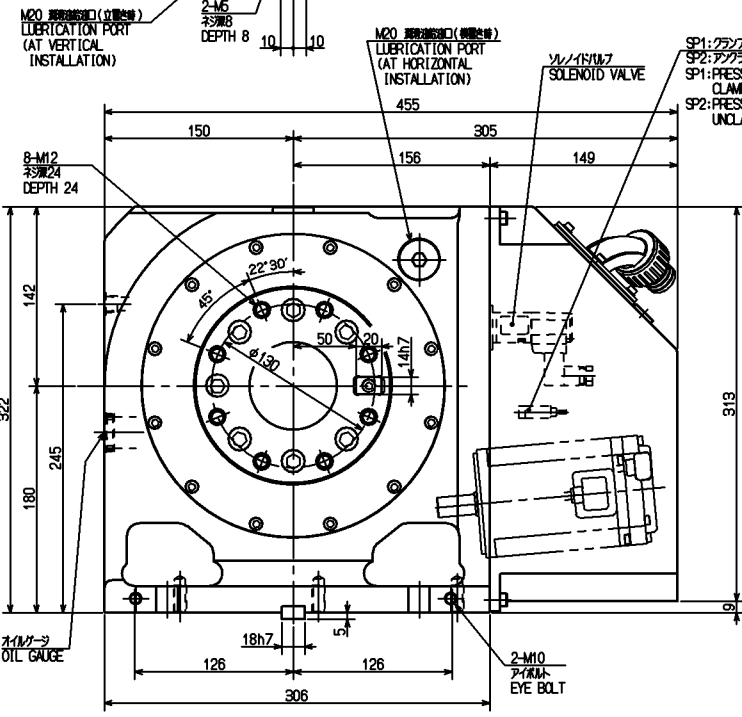
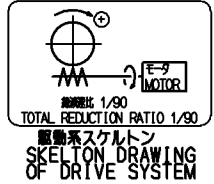

CAREER			SCALE	TYPE	MK250RAV00	WEIGHT	kg
MANAGER			1:3	NCテーブル NC ROTARY TABLE			
CHIEF			3D ANGLE	NAME			
DRAWN BY				MK250RAV00 ガイキ			
DATE			DRW NO.	61E 28 6791			
Kitasawa Corporation				0			